

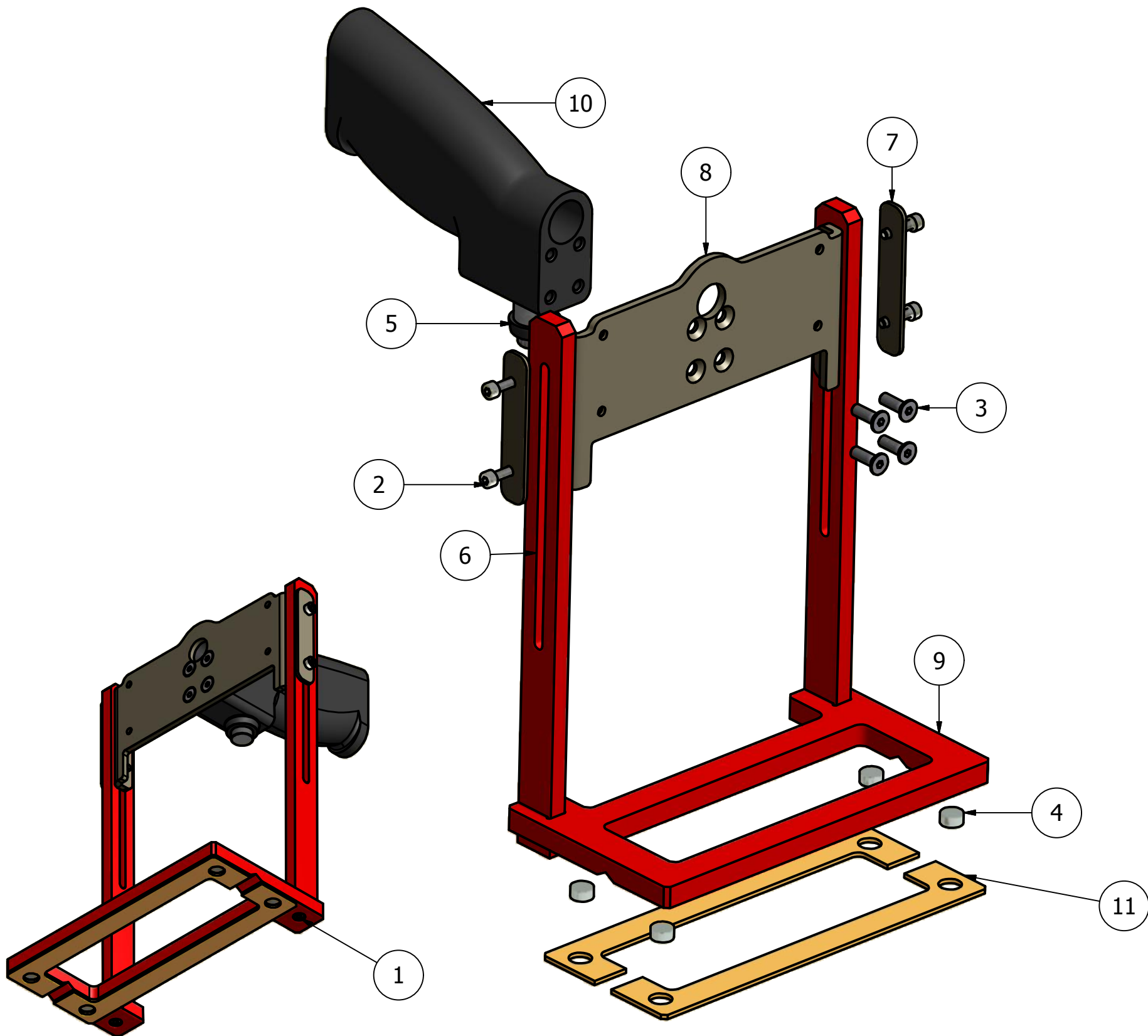

COMPONENT LIST

REF	Q.TY	PART NUMBER	DESCRIPTION
1	2	00101M04012	Screw M4x12
2	4	00101M04016	Screw M4x16
3	4	00102M05016	Screw M5x16
4	4	00136010005	Magnet D10 x 5
5	1	00242001840	Pushbutton
6	2	50106000388	Support
7	2	50111000160	Plate
8	1	50111000389	Support
9	1	50134000386	Support
10	1	50138000275	Handle
11	2	50140000387	Rubber



5				HOUSTON ALLIANCE MARKING SYSTEM 	DESIGNER
4					DATE
3					26/02/2012
2					SCALE
1					1.2
N°	description of modification		DATE	NAME	N° PIECES
Dimension quote = mm					1
Part name				Stand-off ADP25120	
DRW NUMBER		MACHINE	MATERIAL	TREATMENT	REEV.
80103000106		ADP			00
This drawing is our property and must not be shown to third person unless in its original form. Markfirst reserves the right to make changes without notice					